



Toro[®]
Dingo[®]
Compact Utility Loaders



What makes the Toro® Dingo® the **top-selling** compact utility loader?



Simply put, you'll save labor while getting more done. The compact-equipment equivalent of a Swiss Army™ knife, the Toro Dingo is the most versatile, reliable and hardest working compact utility loader on the market.

From Augering, Earth Moving, Tilling And Trenching To Leveling, Lifting, Hauling And Demolishing ... The Options Are Endless.

Imagine all the jobs you can do and the time you can save. Every labor-saving Dingo model gives you effortless maneuverability with a short learning curve — even for inexperienced operators. No wonder it's the top-selling compact utility loader available today.

Many Models With One Goal: Productivity.

At Toro, innovative product development teams continue to make the line of Dingo compact utility loaders better, stronger and more versatile, helping you change your business for the better. The family includes both gasoline and diesel options, as well as wheeled and tracked choices in walk-behind and ride-on designs. Any model you choose offers amazing hydraulic power, all in a compact, maneuverable package.

- Hydraulic power supplied where you need it most — to the drive wheels, tracks, or hydraulic attachments.
- 20 to 27 hp engines available.
- Traction to take on hills, mud or sand.
- Gentle on turf.

Toro Dingo Has The Power To Transform Your Business.

- Maximize manpower and minimize hand labor.
- Increase productivity and finish jobs faster.
- Take on more work and expand your business.
- Tackle virtually any task using a multitude of attachments.
- Work in tight spots where other machines can't reach.
- Go almost anywhere with a light footprint on existing turf.



220



323



320D



TX 427



TX 427 Wide Track



TX 525



TX 525 Wide Track

Determine The Toro Dingo That's Right For You.

While your operation's specific needs should be discussed with your Toro dealer, here are a few general advantages for each model type. For more information, visit toro.com/dingo.

Tracked Models

- Improved flotation for better traction and a light footprint in sandy or wet ground conditions
- Higher operating capacity for added lifting ability
- Operator-friendly controls

VS.

Wheeled Models

- Better maneuverability in tight spaces, due to short wheelbase design
- Longer tire wear on hard surfaces, plus faster transport speeds
- Improved visibility of working area from integrated operator platform

Gas Models

- Easier "do-it-yourself" maintenance and lower repair costs
- Better starting in cold conditions
- Readily available fuel
- Lower up-front investment

VS.

Diesel Models

- Better performance in high altitudes and warmer climates
- More net horsepower improves traction and delivers added torque to attachments
- Longer engine life

Toro® Dingo® TX Tracked Models



TX 427 Narrow Track

- Kohler® CH740 gasoline engine
- Two-stage, heavy-duty, remote air cleaner
- Track width – 5.9"
- Width – 33.7"
- Weight w/out bucket – 1882 lbs.
- Light footprint — 5.1 psi ground pressure
- 11.4 gpm auxiliary hydraulic flow



TX 427 Wide Track

- Kohler CH740 gasoline engine
- Two-stage, heavy-duty, remote air cleaner
- Track width – 9.5"
- Width – 41"
- Weight w/out bucket – 2075 lbs.
- Light footprint — 3.6 psi ground pressure
- 11.4 gpm auxiliary hydraulic flow



Toro **defined** the compact utility loader market and we **continue to stay true** to the category.

Toro Dingo TX compact utility loaders possess the versatility to handle countless jobs on every site ... dig, haul, plant and build. Designed by Toro engineers specifically for professionals, the Dingo TX is an innovative, rugged and dependable piece of equipment that shows up for work every day, ready for virtually any job.

These machines are built right ... delivering a high power-to-weight ratio — and the lightest footprint — in the compact utility loader category.

Hydraulic performance beyond the category.

The TX models' auxiliary hydraulic performance makes the most challenging ground conditions irrelevant by pumping 24 hp (diesel) or 19 hp (gas) to the attachment. Four independent hydraulic pumps deliver ...

- 16.9 gpm of flow to each track
- 13.8 gpm (diesel) or 11.4 gpm (gas) to the auxiliary
- 6 gpm to the loader arm

Tackle a lot more work in less time.

- Uses for the Toro Dingo TX and its various attachments are limited only by your imagination.
- Toro's exclusive TX control system (see illustration) is easy to learn; new operators are instantly productive with true command for accurate performance.
- Two-stage, heavy-duty, remote air cleaner is contained under the hood, so it is not prone to damage and sight lines aren't impaired.
- Optional platform allows ride-on capability when traveling long distances.

Make tracks with the Toro Dingo TX loader.

- Durable Kevlar® reinforced tracks offer extended life, unlike competitive units with metal inserts.
- Tracks disperse weight evenly, giving high flotation and a light footprint on turf, yet delivering the necessary traction in loose sand or mud.
- Open design of traction system is self-cleaning, preventing the collection of sand, rocks, mud, and debris that could jam tracks.
- Pound for pound and power for power, these machines are unmatched in their category.

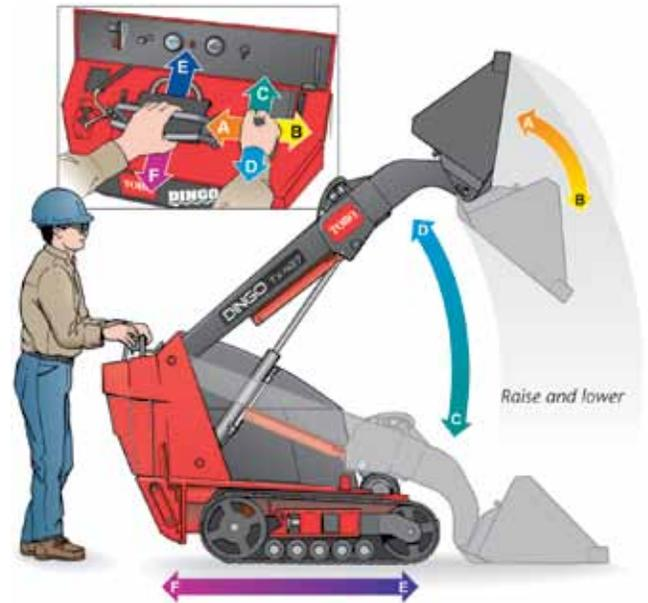

Toro's patented, easy-to-use and learn controls make for more productive workers.

TX 525 Narrow Track

- Kubota® D902 diesel engine
- Two-stage, heavy-duty, remote air cleaner
- Track width – 5.9"
- Width – 33.7"
- Weight w/out bucket – 1904 lbs.
- 5.2 psi ground pressure
- 13.8 gpm auxiliary hydraulic flow



TX 525 Wide Track

- Kubota D902 diesel engine
- Two-stage, heavy-duty, remote air cleaner
- Track width – 9.5"
- Width – 41"
- Weight w/out bucket – 2001 lbs.
- 3.4 psi ground pressure
- 13.8 gpm auxiliary hydraulic flow



Toro® Dingo® Wheeled Models



220

- Kohler® CH20 gasoline engine
- Air-cooled engine
- One, 4-gallon fuel tank
- Standard two-stage air cleaner
- Mechanically driven by hydraulic pumps



323

- Kohler CH23 gasoline engine
- Air-cooled engine
- Two, 4-gallon fuel tanks
- Two-stage, heavy-duty, remote air cleaner
- 4 Paw hydraulic traction control



The original compact utility loaders **packed with the power** you need.

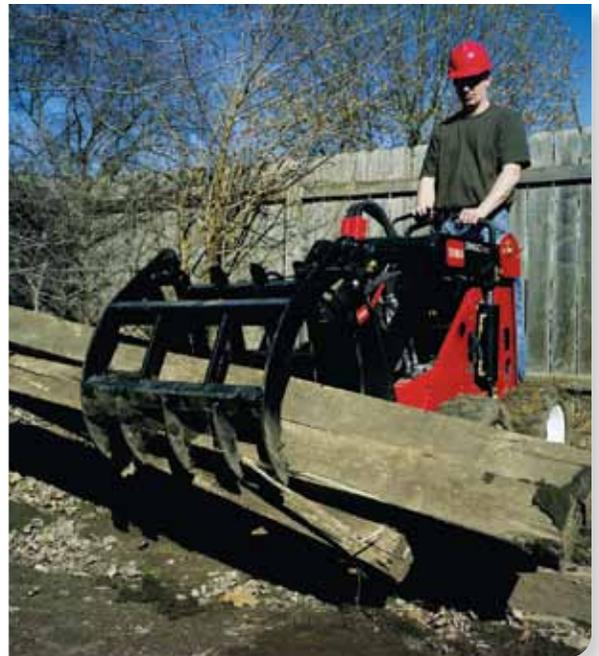

Productive, no matter how you look at it.

- Supporting numerous attachments, the Dingo 220, 323 and 320D will continue to astonish you with what they can accomplish.
- Ride-on platform provides improved visibility of your working area and attachments.
- At only 40.5" wide and with zero-turn capability, you can access confined spaces you never dreamed possible.
- Removable counterweight allows you to add lift capacity or increase down pressure for optimal attachment performance.
- Short length contributes to efficient trailering.

320D

- Kubota® 722 diesel engine
- Liquid-cooled engine
- One, 4-gallon fuel tank
- Two-stage, heavy-duty, remote air cleaner
- 4 Paw hydraulic traction control



4 Paw® independent 4-wheel drive system.

Four independent wheel motors deliver hydraulic flow and pressure to all four wheels at all times on both Dingo 323 and 320D models.

- Improves traction
- Increases mobility
- Reduces chances of getting stuck
- Less moving parts, reducing maintenance

Reliable hydraulic power, time after time.

- Pumping 10.8 gpm @ 3000 psi, these machines have incredible hydraulic power.
- Powerful 2-pump hydraulic system for efficient separation of power to attachments, wheels or loader arms.
- Quick-change dripless flush-face couplers keep hydraulic system clean.



Buckets

- Standard bucket: Holds 4.3 cubic feet; Width: 42"
- Narrow bucket: Holds 3.5 cubic feet; Width: 34.5"
- Light materials bucket: Holds 6.9 cubic feet; Width: 48"
- Optional tooth bars available*



High-Speed Trencher

- Ideal for fast, efficient trenching in most soil conditions
- 24", 36" and 48"* booms available
- Auger speed: 187 rpm at 11gpm
- Torque: 442 ft/lbs at 3000 psi
- *Optional auger recommended for 4' boom



High-Torque Trencher

- Guarantees performance in difficult soil conditions
- 24", 36" and 48"* booms available
- Auger speed: 120 rpm at 11gpm
- Torque: 675 ft/lbs at 3000 psi
- *Optional auger recommended for 4' boom



Leveler

- Grade, finish, and spread topsoil and other landscape materials
- Back fill trenches
- Carry job site materials such as plants, fertilizer, irrigation supplies, and more
- Length: 36"; Width: 49"; Height: 16"



Trench Filler

- Two sets of opposing augers direct spoils into the hole
- Standard float mechanism allows for up to 5" of ground following floatation
- Skids evenly disperses weight and slide easily over turf, minimizing damage
- Overall width: 62"; Working width: 48"; Auger diameter: 14"; Float distance: 6"



Utility Blade

- Designed for versatility, this 48" blade angles 30° both right and left with the flip of a lever
- The blade can be removed and rotated 180° to increase blade life
- Overall width: 48"; Overall height: 20.75"



Bore Drive Head and Rod & Reamer Kit (sold separately)

- Easily bore under driveways and sidewalks to simplify irrigation and cable installations Working depth: 19.38"
- Standard Rod & Reamer Kit: Boring Bit: 1.75"; Reamer: 2.5"; Drill rods (4): .875" diameter, by 5'. Optional bits from 1.25"-2.5"; Optional reamers up to 4.5"



Vibratory Plow

- Optimizes pipe-pulling performance while minimizing turf damage to reduce time and labor spent on irrigation or cable installations
- Pulls pipe up to 18" deep and 2" in diameter
- Max. plow speed: 88 ft/min depending on soil conditions.



TX Platform

- Bolts easily onto any Toro Dingo TX model
- Special pivot point allows platform to follow the terrain, increasing operator comfort and safety
- Platform can be flipped out of the way at any time
- Width: 29"; Operating height from ground: 5"



High-Torque Auger Power Head

- Designed specifically to power up to 30" diameter augers in the toughest soil conditions
- Excellent for digging holes for trees, footings or irrigation valve boxes 1514 ft/lbs. of torque @ 3000 psi
- Auger bits from 6" to 30"
- 1' and 2' extensions available



Universal Swivel Auger Power Head

- Ensures "plumb" holes on uneven terrain up to 18"
- Perfect for installing fences
- Torque: 1060 ft/lbs at 3000 psi @ 11 gpm
- Bit length 42"; 1' and 2' extensions available



Cement Bowl

- Flighting mixes and holds cement in bowl
- Mix, haul, and pour up to 200 lbs
- Auger power head required (sold separately)



Stump Grinder

- Great for getting into areas most other grinders can't
- Index position of wheel adjusts up to 30°, allowing easy removal of roots
- Cuts up to 36" above and 16.5" below grade
- Wheel diameter: 17"; Teeth count: 12 carbide tipped



Tree Forks

- Hydraulic fork arm opens to handle large trees and shrubs
- Angle design allows for gentle handling of materials
- Opening at tip: 25"



Grapple Rake

- Exceptional power for clamping and holding
 - Ideal for picking up and removing trees, bushes, roots and rocks — as well as demolition and construction debris
 - Tines constructed of 3/8" AR400 steel*
- NOTE: Nearly twice as hard, 50% better wear than T1 steel



Tiller

- Hardened steel tines for any soil condition, including clay or hardpan
- Till more than six inches deep and 40" wide on one pass
- Reversible tine direction frees jams quickly
- Overall width: 44"



Soil Cultivator

- Bury stones, soil clods, debris and grass
- Prepares seed bed in one pass, tilling soil up to 5.5" deep
- Adjustable grading bar and comb teeth leave perfect germination environment
- Working width: 36"; Overall width: 51"



Power Box Rake

- Perfect tool for seed or sod bed preparation
- Carbide-teeth rotary drum pulverizes rough soil, cuts high spots and fills low spots in one pass
- Manually adjustable yoke allows 20° offset
- Overall width: 67"; Working width: 48"



Hydraulic Breaker

- Horizontal and vertical positions for demolishing driveways, sidewalks, steps, or walls
- Powerful; delivers 180 ft/lbs of force and up to 1250 blows per minute



Adjustable Forks

- Easily adjust forks to desired width
- Carry fence posts, rocks, pallets, plants, fertilizer, irrigation supplies and more
- Forks constructed of high-strength T1 steel
- Lift capacity: 335 lbs.; Maximum lift height: 61"



Backhoe

- Versatile — dig foundations, plant trees, trench and much more
- Folds to 34.5" wide for access to tight spaces and ease of transport
- 180° bucket and swing arm rotation, 82" digging depth, and standard 13" bucket
- Stabilizer spread: 78"



Snowthrower

- Two-stage design with the power to handle the toughest snow conditions
- Replaceable scraper
- Adjustable skids
- Overall Width: 48"; Clearing width 44"
- Auger diameter: 16"; Auger speed: 161 rpm @ 11 gpm



Multi-Purpose Tool

- 3 tools in 1: ripper, towbar, boom
- Ripper: 3 thick steel tines — great for digging & breaking up soil
- Towbar: Accepts ball with 1" diameter threads (ball not included)
- Boom & chain length 45"; ideal for planting and hauling trees and shrubs

See parts catalog for details.

auger
bore
build
carry
clear
cultivate
demolish
dig
grade
grind
haul
level
lift
load
mix
move
plant
plow
pour
prep
rake
rip
scoop
sweep
till
tow
transport
trench

Genuine Toro® Dingo® Attachments

Superior design for long-lasting, dependable performance and the perfect fit.

Genuine Toro® Dingo® attachments are your best assurance for attaining a long life and peak performance from your loader. Toro offers a multitude of attachments that are designed specifically for, and fit the front of, the Dingo machine. The attachments are easy to operate, delivering clear sight lines, excellent operator mobility, plus easy on and off — typically in seconds.

Protect your investment by using only genuine Toro attachments that include ...

- **Optimized performance** that comes from attachments Toro engineers specifically designed for the Toro Dingo.
- **Shielded seals** on hydraulic attachments, providing two protective components to the vital hydraulic mechanism.
- **Heavy-duty, high-performance hydraulic motors** with flow and pressure ratings designed for optimal operation and life of the equipment.
- **Heavy-duty** bearings working in the heart of each design for longer life.
- **High-abrasion-resistant materials** on all ground-engaging parts, proven to sustain years of heavy use.

Change attachments in seconds with no lifting. Easy as 1-2-3.



1) Mount to the attachment plate on the unit.



2) Twist pins to locked position.



3) For powered attachment, connect hydraulic lines to dripless flush-face quick couplers on loader arms.

TORO® DINGO® TX TRACKED MODELS SPECIFICATIONS

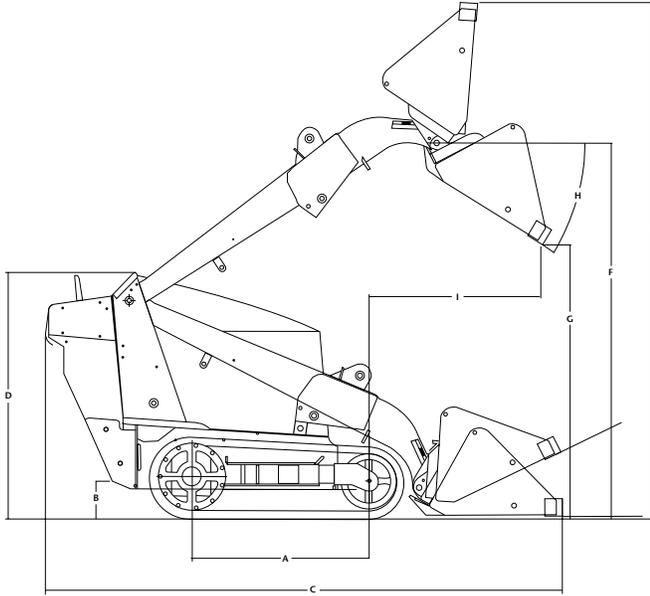

TX 525	Kubota® D902E3B diesel engine
TX 525 Wide Track	Kubota D902E3B diesel engine
TX 427	Kohler® Command Pro® Series CH740
TX 427 Wide Track	Kohler Command Pro Series CH740

ENGINE

Air Filter	Models TX 427/525: Two-stage, heavy-duty, remote
Cooling System	Models TX 525: Liquid cooled Models TX 427: Air cooled
Fuel Tank	Models TX 525/TX 427 – 6 gallons (23 liters)
Oil Capacity	Models TX 525 – 3.84 quarts (3.63 liters) Models TX 427 – 2 quarts (1.9 liters)

HYDRAULIC SYSTEM

Pressure	Models TX 525/TX 427 – 3000 psi
Flow	Models TX 525/TX 427 – 6 gpm loader arm Models TX 525/TX 427 – 16.9 gpm traction (each pump) Models TX 427 – 11.4 gpm auxiliary Model TX 525 – 13.8 gpm auxiliary
Reservoir Capacity	Models TX 525/TX 427 – 10.5 gallons (40 liters)
Auxiliary Horsepower	Models TX 525; 24 hp Models TX 427; 20 hp

TRACK

Standard	Endless Kevlar reinforced rubber with single internal tooth drive Wide track models: 96.6" x 9.5" Standard track models: 96.6" x 5.9"
----------	---

TRACK DRIVE

Standard	Sprocket-drive, 10 road wheels per side, cast iron track guide
Traction	Dual hydrostatic pump

DIMENSIONS

	TX 525	TX 525 Wide Track	TX 427	TX 427 Wide Track
Track Width	5.9"	9.5"	5.9"	9.5"
A Wheelbase	31.2" (79 cm)	31.2" (79 cm)	31.2" (79 cm)	31.2" (79 cm)
B Ground Clearance	4.6" (11.7 cm)	4.6" (11.7 cm)	4.6" (11.7 cm)	4.6" (11.7 cm)
C Overall Length	92" (233.7 cm) w/ bucket; 70.7" (180 cm) w/o bucket	92" (233.7 cm) w/ bucket; 70.7" (180 cm) w/o bucket	92" (233.7 cm) w/ bucket; 70.7" (180 cm) w/o bucket	92" (233.7 cm) w/ bucket; 70.7" (180 cm) w/o bucket
Overall Width	33.7" (85.6 cm)	41" (104 cm)	33.7" (85.6 cm)	41" (104 cm)
D Overall Height	46.1" (117.1 cm)	46.1" (117.1 cm)	46.1" (117.1 cm)	46.1" (117.1 cm)
E Maximum Operating Height	90.1" (229 cm)	90.1" (229 cm)	90.1" (229 cm)	90.1" (229 cm)
F Hinge Pin Height	65.8" (167.1 cm)	65.8" (167.1 cm)	65.8" (167.1 cm)	65.8" (167.1 cm)
G Dump Height	46.1" (117.1 cm)	46.1" (117.1 cm)	46.1" (117.1 cm)	46.1" (117.1 cm)
H Dump Angle	38°	38°	38°	38°
I Reach	21.8" (55.4 cm) fully raised	21.8" (55.4 cm) fully raised	21.8" (55.4 cm) fully raised	21.8" (55.4 cm) fully raised
Ground Speed	0.4 mph forward, 0–2 mph reverse	0.4 mph forward, 0–2 mph reverse	0.4 mph forward, 0–2 mph reverse	0.4 mph forward, 0–2 mph reverse
Tip Capacity	1580 lbs. (717 kg)	1580 lbs. (717 kg)	1530 lbs. (694 kg)	1530 lbs. (694 kg)
SAE J818 Rating 50% tip capacity	790 lbs. (360 kg)	790 lbs. (360 kg)	765 lbs. (348 kg)	765 lbs. (348 kg)
SAE J818 Rating 35% tip capacity	553 lbs. (251 kg)	553 lbs. (251 kg)	535 lbs. (243 kg)	535 lbs. (243 kg)
Weight (w/ std. bucket)	2030 lbs. (921 kg)	2127 lbs. (965 kg)	2006 lbs. (910 kg)	2186 lbs. (992 kg)
Weight (w/o bucket)	1904 lbs. (864 kg)	2001 lbs. (908 kg)	1882 lbs. (934 kg)	2075 lbs. (934 kg)
Ground Pressure	5.2 psi	3.4 psi	5.1 psi	3.5 psi

Get More From Toro



Extended Protection Plan

To help preserve your investment and provide assurance of your long-term satisfaction, Toro® offers the equipment industry's most comprehensive protection against unwanted repair bills. When your Toro warranty expires, Toro Protection Plus begins immediately and delivers peace of mind for the duration of the plan you purchased. (Not available in Canada.)

TORO DINGO WHEELED MODELS SPECIFICATIONS

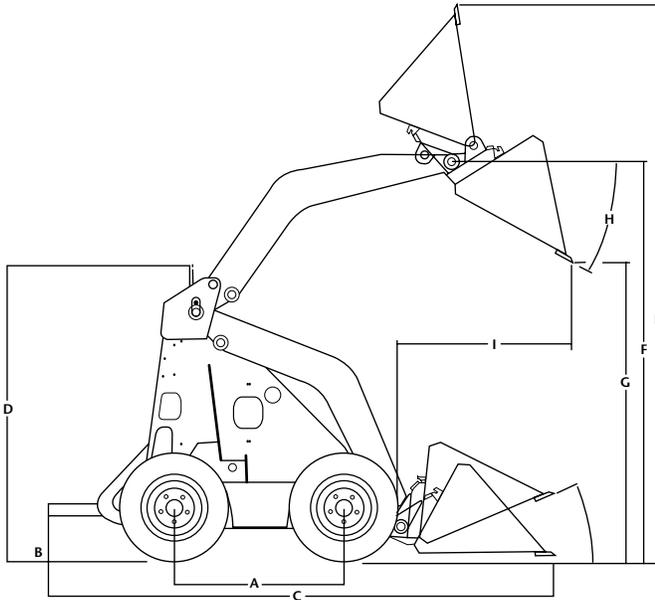

323	Kohler® Command Series CH23
320D	Kubota® D722-E3B
220	Kohler Command Series CH20

ENGINE	
Cooling System	Models 323/220: Air cooled Model 320D: Liquid cooled
Fuel Tank	Model 323 – 2 tanks, 4 gallon (15 liter) capacity each Models 220/320D – 1 tank, 4 gallon (15 liter) capacity with pre-cleaner
Oil Capacity	Models 323/220 – 2 quarts (1.9 liter) Model 320D – 3.4 quarts (3.2 liter)
Air Filter	Models 323/320D – Two-stage, heavy-duty, remote air cleaner Model 220 – Standard dry-type

HYDRAULIC SYSTEM	
Pressure	Models 323/220/320D – 3000 psi system relief pressure
Flow	Models 323/220/320D – 4.0 gpm low-flow hydraulic circuit; 10.8 gpm high-flow hydraulic circuit
Reservoir Capacity	17 gallons (64 liter)

DIMENSIONS

323 / 320D

220

A Wheelbase	28" (71 cm)	28" (71 cm)
B Ground Clearance	5.8" (15 cm) front; 5.8" (15 cm) rear	5.8" (15 cm) front; 5.8" (15 cm) rear
C Overall Length	62" (157.5 cm); 82.2" (208.8 cm) w/bucket	62" (157.5 cm); 82.2" (208.8 cm) w/bucket
Overall Width	40.5" (103 cm) standard tires; 35" (90 cm) narrow tires	40.5" (103 cm) standard tires; 35" (90 cm) narrow tires
D Overall Height	48.7" (123.7 cm)	48.7" (123.7 cm)
E Maximum Operating Height	91.2" (231.6 cm)	91.2" (231.6 cm)
F Hinge Pin Height	66" (167.6 cm) std. bucket – highest position	66" (167.6 cm) std. bucket – highest position
G Dump Height	47" (119 cm) std. bucket	47" (119 cm) std. bucket
H Dump Angle	34° std. bucket	34° std. bucket
I Reach – max.	28" (71.1 cm) std. bucket	28" (71.1 cm) std. bucket
Ground Speed	4.5 mph forward and reverse / 3.0 mph forward and reverse	4.5 mph forward/reverse / 3.0 mph forward and reverse
Tip Capacity	1030 lbs. (467 kg) / 1048 lbs. (146 kg)	1030 lbs. (467 kg)
SAE J818 Rating 50% Tip Capacity w/ 200 lbs. (91 kg) operator	515 lbs. (234 kg) / 524 lbs. (238 kg)	515 lbs. (234 kg)
Weight (w/ std. bucket)	1713 lbs. (777 kg) / 1868 lbs. (847 kg)	1576 lbs. (715 kg)
Weight (w/o bucket)	1567 lbs. (711 kg) / 1722 lbs. (781 kg)	1430 lbs. (649 kg)



Think and Live Safely

Toro cares about the wellbeing of you and your family, and is happy to provide safety training materials that can help protect you, your employees and your business.



For the Toro® Dingo® Dealer Near You ...

Visit toro.com/dingo and use the "Dealer and Rental Locator" to find out where to buy, service or rent a Dingo compact utility loader. Our national network of factory-authorized dealers can also provide you with genuine Toro parts and service support.



Genuine Toro Parts

With Toro, quality and service don't end when you take delivery of your equipment. Genuine Toro parts are designed specifically for your machine to ensure it performs as intended.

Toro's commitment to you extends deep into our heritage and is demonstrated by our industry-leading 98% fill rate, full one-year warranty and on-time delivery. With Toro, you get much more than quality equipment, you get commitment and dedication from hundreds of people to ensure the uninterrupted productivity and durability of your equipment.

Pro Parts Express

Toro's Pro Parts Express program minimizes downtime. Toro's expansive dealer network ensures ready access to the parts and service you will need from time to time. Although our dealers are well stocked, it's not feasible for them to carry every part. When your Toro dealer does not have the part you need, they can order it and have it shipped to you directly from Toro, saving you precious time. Now that's superior customer service. Ask your dealer about Toro Pro Parts Express today (not available in Canada).

STX Stump Grinders: Designed for Serious Productivity.

Wet, hilly terrain won't stop you from accessing tough jobs year-round with an STX stump grinder. The tracks travel easily over muddy areas, with a low center of gravity adding side hill stability. And with a hydraulically driven head, there's no chance of expensive belts breaking or slipping and no tension adjustments — guaranteeing optimal performance time after time. The STX fits easily through standard 36" gates and features patented Toro® Dingo® TX-style controls that are simple to learn and use. In short, it's the ideal solution to turn stumps to chips quickly and efficiently.



TRX Tracked Trenchers Deliver Stability, Maneuverability ... and Toro's Proven Reliability.

Operator-friendly controls plus a low-profile tracked design make TRX walk-behind trenchers easy to use and more stable and maneuverable on almost any terrain — which means faster trenching and faster profits for you.

Call your local Toro dealer today or visit toro.com/professional for more information.



Products depicted in this literature are for demonstration purposes only. Actual products offered for sale may vary in use, design, required attachments and safety features. We reserve the right to improve our products and make changes in specifications, designs and standard equipment without notice and without incurring obligation. See your dealer for details on all of our warranties.

