



BOMAG

FAYAT GROUP

Multi-Purpose Articulated Compactor

BMP8500



Water cooled Kubota engine with ECOMODE (Fuel Saver).



Easy installation of standard bolt-on drum extensions increases compactor versatility.



Light weight, dual function cable / radio remote control is easy and safe to operate.

Technical Specifications

BMP8500

Shipping dimensions

in cubic feet (m³)

BMP8500

77.7

(2.2)

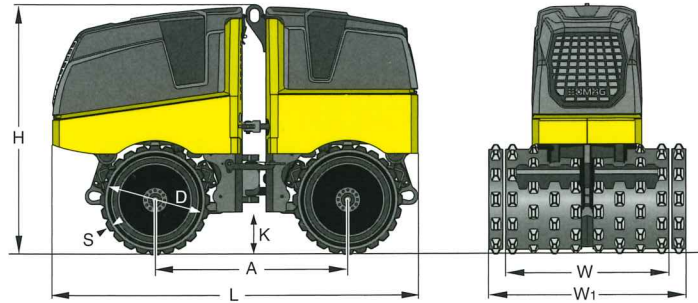

Dimensions in inches (mm)

	A	D	H	K	L	S	W	W ₁
BMP8500	39.4 (1000)	20.5 (520)	50.2 (1275)	8.7 (222)	74.7 (1897)	1.0 (25)	24.0 (610)	33.5 (850)

Standard Equipment

- ✓ Articulated steering
- ✓ Dual function cabled / radio remote control box
- ✓ Standard dual (2) working widths of 24 and 33.5 inches
- ✓ 1 inch padfoot height
- ✓ High centrifugal force and amplitude
- ✓ 2 selectable amplitudes
- ✓ Double exciter system with directed vibration
- ✓ Intelligent Vibration Control (IVC)
- ✓ 2 scrapers per drum
- ✓ Water cooled Kubota engine with ECOMODE
- ✓ 2 travel speed ranges
- ✓ Spring-Applied, Hydraulically-Released (SAHR) parking brake
- ✓ Balanced, hinged center lift point
- ✓ Swing out/up covers
- ✓ Lockable hoods
- ✓ Easy service concept
- ✓ Diagnostic module with failure codes
- ✓ Diesel filter with water separator
- ✓ BOSS - BOMAG Operator Safety System

Technical data

Weights

Basic Weight	lbs (kg)	3495 (1585)
Operating Weight CECE	lbs (kg)	3517 (1595)
Average axle load CECE	lbs (kg)	1811 (822)

Dimensions

Working width	in (mm)	24.0/33.5 (610/850)
---------------	---------	---------------------

Driving Characteristics (depending on site conditions)

Speed(1), forward / reverse	mph (kmph)	0-0.8 (0-1.3)
Speed(2), forward / reverse	mph (kmph)	0-1.6 (0-2.5)
Max. gradeability without/with vibration	%	55/45

Drive

Engine manufacturer and Type	Kubota D1005
Emission Standard	Tier 4
Cooling	Water
Number of cylinders	3
Performance ISO 9249	19.4 (14.5) hp (kW)
Speed	2600 rpm
Fuel	Diesel
Drive system	Hydrostatic
Drum drive	Front + Rear

Brakes

Service brake	Hydrostatic
Parking brake	SAHR

Steering

Steering system	Articulated
Steering method	Hydrostatic
Steering angle +/-	32 degrees

Vibratory system

Vibrating drum	Front + Rear
Drive system	Hydrostatic
Frequency	2520 (42) vpm (Hz)
Amplitude	0.022/0.044 (0.56/1.12) in (mm)
Centrifugal force	8000/16000 (36/72) lbs (kN)

Capacities

Fuel	gal (l)	6.3 (24)
------	---------	----------

Technical modifications reserved. Machines may be shown with options.



BOMAG
FAYAT GROUP

BOMAG Americas, Inc.

125 Blue Granite Parkway

Ridgeway, SC 29130 • Tel: 803 337-0700